

User Instructions

Gas fired condensing combi boiler

Greenstar 8000 Life

GR8300iW 30 C | GR8300iW 35 C | GR8300iW 40 C | GR8300iW 45 C | GR8300iW 50 C



Preface

Dedicated to heating comfort.

Thank you for purchasing a Worcester product. We pride ourselves on manufacturing appliances to the strictest quality control standards throughout every stage of production.

Worcester, Bosch group has led the field in innovative product design and performance for over 50 years. This heritage means all our products are of exceptional quality and proven reliability.

Our products employ the latest technologies and they are reliable, extremely energy efficient, offering you economical running costs and value for money. They are amongst the top energy rated appliances available.

There is also the reassurance of our parts and labour guarantee. Our Customer Service team is here to help you get the best from your Worcester product throughout its lifetime. Whatever your enquiry, our specially trained team is available at our Worcester based contact centre and online via the website. For contact details see the back cover.

Table of contents

1	Explanation of symbols and safety instructions	3
1.1	Explanation of symbols	3
1.2	General safety instructions	4
2	Product Information	5
2.1	Appliance identification and serial number	5
2.2	Servicing	5
2.3	Maintaining your appliance	5
2.4	Benchmark standard	6
3	Prepare for operation	6
3.1	Open vented heating system	6
3.2	Sealed heating system	6
3.2.1	Checking the system pressure	6
3.2.2	Constantly re-pressuring the system pressure	6
3.3	Topping up the system pressure	7
3.3.1	Greenstar Intelligent Filling System (accessory)	7
4	Operating the appliance	7
4.1	Control panel overview	7
4.2	Symbols in the display	7
4.3	Adjusting the appliance flow temperature	8
4.3.1	Heating key	8
4.4	Hot water mode	8
4.4.1	Hot water key	8
4.5	eco key	8
4.6	Selecting current pressure	8
5	Key (accessories)	8
5.1	Installing the Key	8
5.2	Key LED	9
6	Shutdown	9
6.1	Setting frost protection	9
7	Clearances and ventilation information	9
7.1	Appliance clearances	9
7.2	Ventilation information	9
8	Malfunction or failure	10
8.1	Troubleshooting	10
8.2	Extreme cold weather	10
9	Environmental protection and disposal	11
10	Tips on energy saving	11
11	Your guarantee	11
12	Energy consumption	12
12.1	Product data on energy consumption	12

1 Explanation of symbols and safety instructions

1.1 Explanation of symbols

Warnings

In warnings, signal words at the beginning of a warning are used to indicate the type and seriousness of the ensuing risk if measures for minimising danger are not taken.

The following signal words are defined and can be used in this document:

DANGER:

DANGER indicates that severe or life-threatening personal injury will occur.

WARNING:

WARNING indicates that severe to life-threatening personal injury may occur.

CAUTION:

CAUTION indicates that minor to medium personal injury may occur.

NOTICE:

NOTICE indicates that material damage may occur.

Important information



The info symbol indicates important information where there is no risk to people or property.

Additional symbols

Symbol	Meaning
▶	a step in an action sequence
→	a reference to a related part in the document
•	a list entry
–	a list entry (second level)

Table 1

1.2 General safety instructions

⚠ Instructions for the target group

These operating instructions are intended for the heating system user.

All instructions must be observed. Failure to comply with instructions may result in material damage and personal injury, including possible loss of life.

- ▶ Read and retain the operating instructions (heat source, heating controller, etc.) prior to operation.
- ▶ Observe the safety instructions and warnings.

⚠ Determined use

The product may only be used for the heating of boiler water and for DHW heating.

Any other use is considered inappropriate. We assume no liability for damage occurring due to non-permitted use.

⚠ If you smell gas

A gas leak could potentially cause an explosion. If you smell gas, observe the following rules:

- ▶ Prevent flames or sparks:
 - Do not smoke, use a lighter or strike matches.
 - Do not operate any electrical switches or unplug any equipment.
 - Do not use the telephone or ring doorbells.
- ▶ Turn off the gas at the meter or regulator.
- ▶ Open windows and doors.
- ▶ Warn your neighbours and leave the building.
- ▶ Prevent anyone from entering the building.
- ▶ Move well away from the building: call the National Gas Emergency Service on 0800 111 999.
- ▶ L.P.G. boilers: Call the supplier's number on the side of the gas tank.

⚠ Danger to life from poisoning by flue gas

There is a danger to life from escaping flue gas.

▶ Never modify any parts through which flue gas is routed.

If flues are damaged or leaking, or if you smell flue gas, observe the following rules.

- ▶ Switch off the heat source.
- ▶ Open doors and windows
- ▶ Warn your neighbours and leave the building immediately.
- ▶ Prevent third parties from entering the building.
- ▶ Notify an approved contractor.
- ▶ Have any defects rectified.

⚠ Danger to life from carbon monoxide

Carbon monoxide (CO) is a poisonous gas, which arises during the incomplete combustion of fossil fuels such as oil, gas or solid fuels.

Dangers arise, if carbon monoxide escapes from the heating system due to a fault or a leak and collects unnoticed in enclosed spaces.

You can neither see, taste nor smell carbon monoxide.

To avoid danger from carbon monoxide:

- ▶ Have the heating system inspected and serviced regularly by an approved contractor.
- ▶ Use a CO detector, which gives an alarm in good time if CO escapes.
- ▶ If you suspect a CO leak:
 - Warn your neighbours and leave the building immediately.
 - Call an approved contractor.
 - Have any defects rectified.

⚠ Inspection and maintenance

If there is a lack of cleaning, inspection or maintenance, or if these are carried out incorrectly, this may result in material damage and/or personal injury, including possible loss of life.

- ▶ Have work carried out only by an approved contractor.
- ▶ Have any defects rectified immediately.
- ▶ Have the heating system inspected once a year by an approved contractor, and have any required maintenance or cleaning work carried out.
- ▶ Have the heat source cleaned at least every two years.
- ▶ We recommend that you enter into a contract covering an annual inspection and needs-based maintenance with an approved contractor.

⚠ Fittings and modification

Only a competent engineer can remove the appliance case and carry out any work, in accordance with the relevant Installation Regulations.

Any misuse or unauthorised modifications to the appliance, flue or associated accessories and heating system will invalidate the guarantee.

- ▶ Do not modify the appliance or flue system in any way.

Worcester, Bosch Group accepts no liability arising from any such actions. This does not affect your statutory rights.

⚠ Combustion air/ambient air

The air in the installation location must be free of flammable or chemically aggressive substances.

- ▶ Do not store or use any highly flammable or explosive materials (paper, petrol, thinners, paints etc.) within the vicinity of the heat source.
- ▶ Do not store or use any corrosive substances (solvents, adhesives, chlorinated cleaning agents, etc.) within the vicinity of the heat source.

⚠ General considerations

- ▶ The boiler must be installed in a well ventilated area. The openings must be kept in good condition.
- ▶ The vents or any other component contributing to the functioning of the boiler must not be reduced or sealed.
- ▶ We recommend an annual service of the appliance by an approved engineer to ensure reliable and efficient operation.

⚠ Safety of electrical devices for domestic use and similar purposes

The following requirements apply in accordance with EN 60335-1 in order to prevent hazards from occurring when using electrical appliances:

“This appliance can be used by children of 8 years and older, as well as by people with reduced physical, sensory or mental capabilities or lacking in experience and knowledge, if they are supervised and have been given instruction in the safe use of the appliance and understand the resulting dangers. Children shall not play with the appliance. Cleaning and user maintenance must not be performed by children without supervision.”

“If the power cable is damaged, it must be replaced by the manufacturer, its customer service department or a similarly qualified person, so that risks are avoided.”

⚠ Please read these instructions carefully

- ▶ These instructions are applicable to the Worcester, Bosch Group appliance model/s stated on the front cover only.
- ▶ These instructions apply in the UK/IE only and must be followed except for any statutory obligation.

2 Product Information

2.1 Appliance identification and serial number

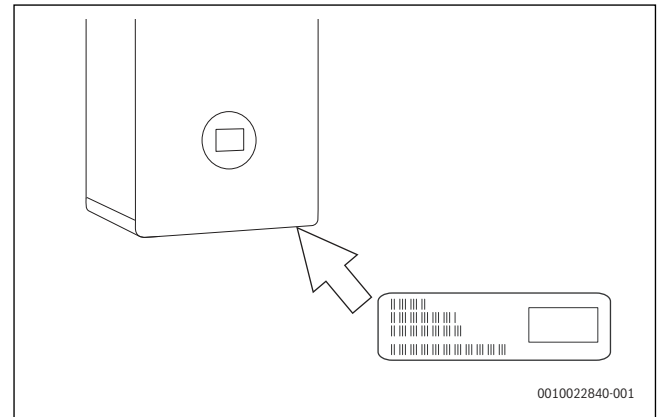

Fig. 1 Position of data label

The data label contains information of the appliance model and serial number. This is located on the frame of the front cover.

For your own records

Please ensure that the Commissioning Checklist has been completed by your installer or service engineer.

Model:	
Serial number:	
Date of installation:	

Table 2 Appliance details

The appliance model and serial number can be found on the appliance data label.

2.2 Servicing



Ensure that the service engineer completes the Service Record in the Benchmark Checklist after each service.

The Service Record can be found at the rear of the appliance’s Installation and Maintenance Instructions. It will be required in the event of any guarantee work and may be required by the local Building Control Inspector.

- ▶ The appliance must be serviced annually by a competent, qualified person, such as a Worcester service engineer or other Gas Safe registered engineer.
- ▶ Ensure that the service engineer completes the Service Record, at the rear of the Installation and Maintenance Instructions manual, after each service.
- ▶ Have any work carried out by a competent, qualified person, Worcester service engineer or other Gas Safe registered engineer.
- ▶ Always use original spares, to help maintain the efficiency, safety and reliability of the appliance.

2.3 Maintaining your appliance

Your new appliance represents a long term investment in a reliable, high quality product.

Wipe the appliance casing with a soft clean cloth. Please do not use chemical cleaning products which may damage the paint finish.

In order to realise the appliance's maximum working life, and to ensure the appliance continues to operate at peak efficiency and performance, it is essential that servicing and maintenance checks are performed at least once a year by a competent engineer in accordance with the current Gas Safe Regulations.

If you would like to know more about servicing options from Worcester, Bosch Group, please visit worcester-bosch.co.uk.

Please tick the appropriate box on your warranty registration card for further details of the Worcester, Bosch Group Service Contract.

When your appliance requires servicing please contact a Worcester, Bosch Group contact centre (see rear cover, appointments).

In addition to the service contract we are pleased to offer a one-off annual service or breakdown call out for your appliance.

Maintenance tips

- Appliances on a sealed heating system:
 - Regularly check the system pressure.
- Do not obstruct the flue outlet or the air inlet.
- Use in hard water areas:
 - In exceptionally hard water areas a device to prevent scale formation may be fitted. Installation of a salt based water softener should be in accordance with the requirements of the local water company. A bypass valve must be fitted and used to fill/top up the heating system with untreated water.



Important note:

- ▶ If you have to add water regularly in your heating system, call a competent, qualified person.

2.4 Benchmark standard



The Benchmark initiative is a code of practice to encourage the correct installation, commissioning and servicing of domestic central heating appliances and system equipment.

A "checklist" is dispatched with every appliance and can be found towards the back of the Installation, Commissioning and Servicing Instructions. This is a vital document that needs to be completed by the installer at the time of installation. It confirms that the appliance has been installed and commissioned according to the manufacturer's instructions.

The service record provides space for the recording of regular servicing of the appliance/heating system and this can become a valuable document when, for example, you wish to sell the property. The service record will show a potential purchaser that the heating system has received regular professional maintenance and servicing during its lifetime.

The Benchmark initiative aims to:

- Raise standards among professional installers.
- Build and maintain high safety standards in the industry.
- Improve customer satisfaction levels.
- Make a contribution to the nation's commitment to climate change.

3 Prepare for operation

3.1 Open vented heating system

Appliances that can be connected to open vented heating systems will have the pressure maintained automatically by the header tank feeding the system.

3.2 Sealed heating system

Appliances that can be connected to sealed heating systems are pre-pressurised before operation, this pressure must be maintained for safe use of the appliance.

- ▶ Check regularly that the pressure is maintained.
- ▶ Re-charge the system if the display reads less than 1 bar.
- ▶ If a permanent significant decrease or increase in pressure is indicated on the display, contact your installer or maintenance engineer.

3.2.1 Checking the system pressure



If the pressure is too low (≤ 0.2 bar) the system is out of operation and the warning notification **LoPr** alternating with the actual pressure stays on the screen.

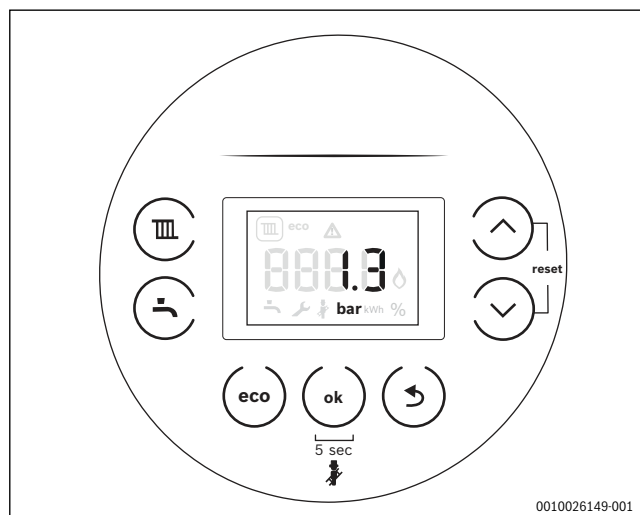

Fig. 2 Actual pressure

Your installer will advise you of the optimum operating pressure.

- ▶ Press the **OK** key.
The actual pressure appears.
- ▶ Top up the heating water, if the pressure is low (≤ 0.8 bar) or too low (≤ 0.2 bar).

3.2.2 Constantly re-pressuring the system pressure

Constantly having to re-pressuring the heating system should be investigated as the concentration of inhibitor protection in the system will be reduced; this can result in corrosion within the heating system reducing the efficiency and increasing contaminants.

- ▶ Check for leaks on heating system (pipe work and radiator valves).
- ▶ Contact your installer or maintenance engineer if a recurring significant decrease or increase in pressure is indicated on the pressure screen.

3.3 Topping up the system pressure

Integral keyless filling link

Locate the filling link and follow the instructions for re-pressurising the system.

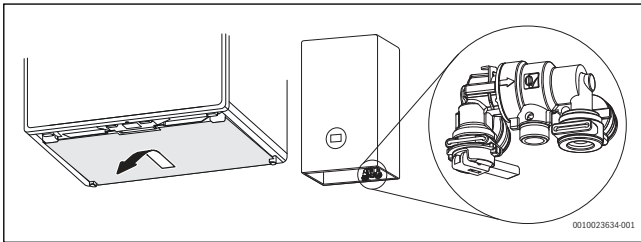

Fig. 3

- ▶ Re-pressurise the system.
 - Pull the lever [1] down to start the filling process.
- ▶ When the pressure, shown on the display, reaches between the 1 and 1.5 bar,
 - Release the lever [1] to stop the filling process.
- ▶ Top up the system pressure, if as a result of the air bleeding the pressure drops off.

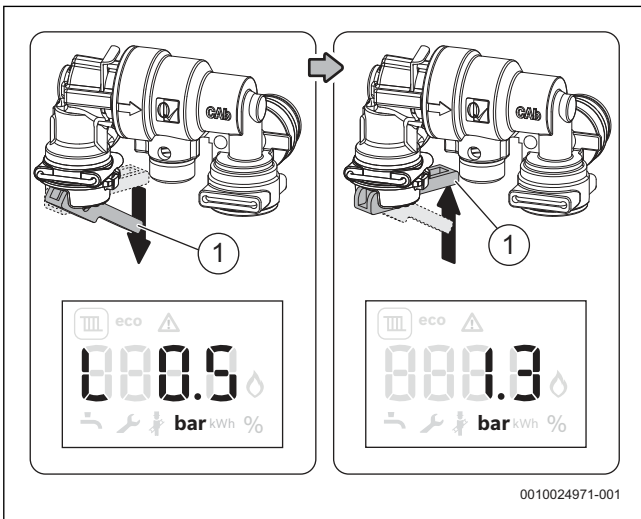

Fig. 4



If the display reads more than 1.5 bar as a result of over filling:

- ▶ Bleed one radiator until the pressure, shown on the display, returns to between 1 and 1.5 bar.

3.3.1 Greenstar Intelligent Filling System (accessory)

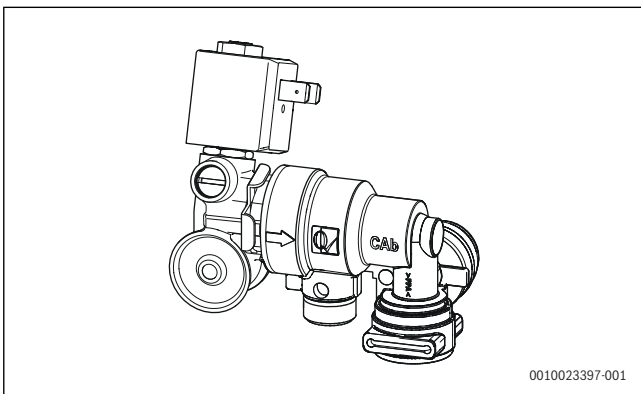

Fig. 5 Greenstar Intelligent Filling System



An Intelligent Filling System is available as an accessory.

The Intelligent Filling System refills the water into the heating system as required. Your specialist programmes the Intelligent Filling System according to your heating system. Have your specialist explain the function of the Intelligent Filling System to you.

Automatic refilling keeps the pressure in the heating system at the programmed value.

4 Operating the appliance

4.1 Control panel overview

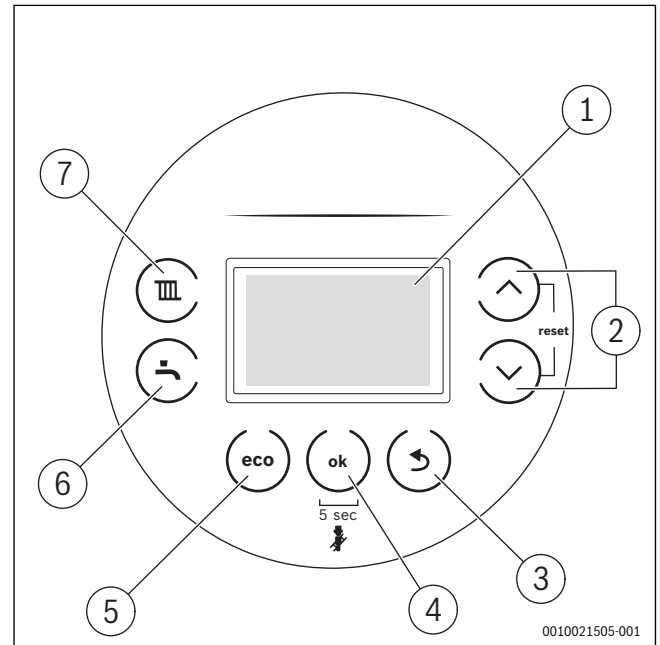

Fig. 6 Control panel

- [1] Display
- [2] ▲ and ▼ keys: To navigate through menus and increase/decrease settings
- [3] ↵ key: Return/back
- [4] OK key: Save settings, Chimney sweeper key (Service Engineer function): press 5 seconds for chimney sweeper mode
- [5] eco key: Hot water preheat selection
- [6] Hot water key: Adjusting the hot water temperature
- [7] Heating key: Heating mode on, set the maximum flow temperature

4.2 Symbols in the display

Symbol	Explanation
	Central heating ON
	Is displayed with the appliance status code and diagnostic code during a fault condition.
	Burner ON/OFF
	Connection with the Wi-Fi network (only available with accessories)
	Connection with RF transmitter, e.g. Comfort+ II RF room thermostat (only available with Key accessories)
	chimney sweep mode



Symbol	Explanation
	Service mode
eco	Eco-Mode
	Hot water ON

Table 3 Symbols in the display



The heating and hot water settings have been adjusted by the installer to the appliance's optimum settings.

- ▶ Before making any adjustments it is advisable to make a note of these settings so that you can return to these optimum settings in the future.



4.3 Adjusting the appliance flow temperature

4.3.1 Heating key

The key is used to set the max. flow temperature. The maximum flow temperature can be set between 30 °C and 88 °C¹⁾. The current flow temperature is shown on the display.



With underfloor heating systems observe the maximum permissible flow temperature.

- ▶ Press the  key.
The set maximum flow temperature appears.
- ▶ Press the  or  keys to set the desired maximum flow temperature.
The setting will be saved after 5s or after pressing the **OK** key .



Supply temperature	Sample application
Approx. 50 °C	Underfloor heating system
Approx. 70 °C	Radiator heating system
Approx. 82 °C	Convactor heating system

Table 4 Maximum flow temperature

4.4 Hot water mode

4.4.1 Hot water key

The hot water temperature can be set between 35 °C and 60 °C.

- ▶ Press the  key.
The set hot water temperature appears.
- ▶ To set the desired hot water temperature, press the  or  keys.
The setting will be saved after 5s or after pressing the **OK** key .

4.5 eco key

Eco mode is an energy saving feature which disables the Preheat function. Eco mode is enabled by default, during the initial appliance startup.

In **Preheat** mode, the hot water heat exchanger is kept pre-heated to reduce the time taken to deliver hot water at the tap.

4.6 Selecting current pressure

- ▶ Press the **OK** key.
The actual pressure appears.

5 Key (accessories)

5.1 Installing the Key



Installing the Key will enable additional functions. For Pairing → Key manual.

Always turn off the power to the appliance before installing Key (accessories).

- ▶ Plug Key into Key housing.

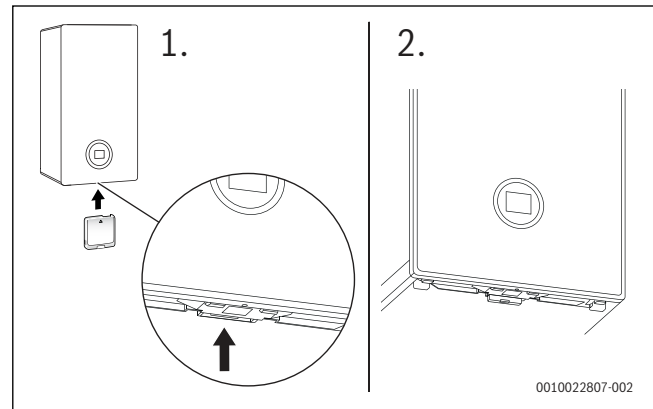

Fig. 7 Position of Key housing

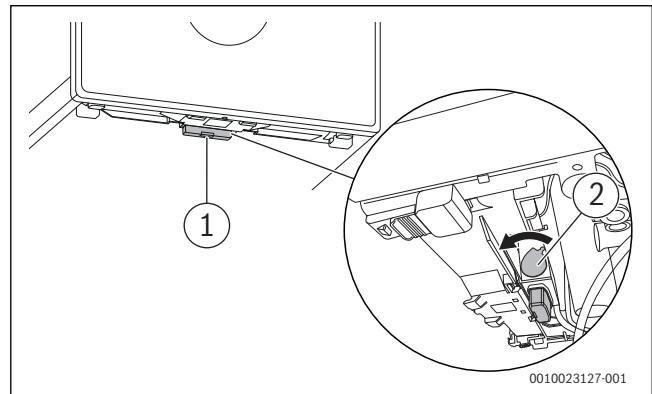

Fig. 8 Locking mechanism

- ▶ The lever [2] of the locking mechanism is located right hand side of the Key housing. Ensure that it is in its Open position before inserting the Key and pulling lever [2] towards front.
- ▶ Turn on the power.
LED [1] starts blinking green.
- ▶ Wait until LED is constantly yellow.

1) The maximum value can be reduced by the service technician.

5.2 Key LED

Key LED status

The LED [1] on the Key displays different states with flashing or constant colours.



Description of the LED displays	Example
Flashing red: Fault, e.g. no communication between the Key and appliance: ► Install the key again, restore the last functioning status.	
Flashing yellow: No fault, user please wait.	
Flashing green: No fault, initialisation process is running.	
Constant red: Temporary fault: ► Wait for normal operating condition to be resumed.	
Constant yellow: No fault, time and date not available: ► Set the time and date on the appliance.	
-or- ► Keys with button: Press button on key to start pairing.	
Constant green: No fault, normal operating condition.	
LED Off: No fault, power-saving mode or appliance without power.	

Table 5 LED status

6 Shutdown

6.1 Setting frost protection

NOTICE:

Risk of damage to the system from frost!

The heating system can freeze up after a prolonged period (e.g. during a power failure, switching off the power supply, faulty fuel supply, boiler fault etc.).

- Ensure that the heating system is in constant use (particularly when there is a risk of frost).

If you are leaving your property unoccupied during cold weather, please leave your external programmer on constant and your room thermostat set to 12 °C.

7 Clearances and ventilation information

7.1 Appliance clearances

Your installer will have provided adequate space around the appliance for operation, safety and servicing/maintenance access.

- The following detail the necessary clearance around the appliance for service and maintenance.



CAUTION:

Risk of damage to appliance or property

The appliance will overheat if the clearance space around the appliance is restricted by objects.

- Do not restrict this space with the addition of cupboards, shelves etc. next to or around the appliance.
- Do not store any combustible materials on or next to the appliance, such as clothes, towels, paper or plastic bags.

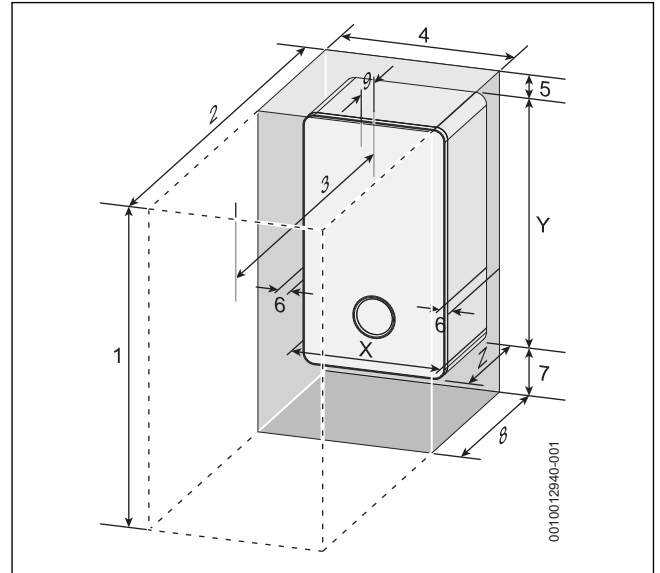

Fig. 9 Appliance minimum clearances

Minimum clearances		
	Description	Dimensions (mm)
X	Appliance width	440
Y	Appliance height	780
Z	Appliance depth	365
Installation/Maintenance		
1	Overall clearance height	1,150/1,190 *
2	Overall clearance depth	965
3	In front of appliance	600
4	Overall clearance width	450
5	Above the appliance	170/210 *
6	Either side of appliance	5
7	Below the appliance	200
8	Compartment depth	385
9	Appliance to removable door	20

Table 6

[*] Height for either 60/100 flue or 80/125 flue

7.2 Ventilation information

The air supply must not be restricted or contaminated.



Ventilation considerations

- Do not place objects to hinder the air circulation required by the appliance.
- The installation premises may require ventilation to be fitted according to its features or use.

8 Malfunction or failure

If you believe there is a problem with your central heating or hot water supply, before you contact your installer/maintenance engineer and report the error and appliance type carry out the following checks.

Basic checks

Some items to check before placing a call are:

- Is the electrical power switched on to the appliance?
- Is the programmer/timer set to ON or in an ON period?
- Is the room thermostat set too low?
- Is the cylinder thermostat (if fitted) set too low?
- Is the cold water main turned on?
- Sealed heating system:
 - Is the static system pressure (when appliance is cold) between 1 - 1.5 bar?
- Do you have gas?
 - Are other gas appliances working, gas cooker/hob for example?
 - Has your credit run out on your gas pre-payment meter?

Details of your installer should be available in the Commissioning Checklist or can be recorded in the following section.

Installer/maintenance engineer

Installer/maintenance engineer details	
Engineer name:	
Company name:	
Company address:	
Telephone:	
Email:	

Table 7

Worcester, Bosch Group

The appliance is supported in the UK and Eire by Worcester, Bosch Group.

Specialist service engineers are available to attend an appliance breakdown.



Invoices for attendance and repair work carried out on this appliance by any third party will not be accepted.

- No charge will be made for parts and/or labour providing:
 - The appliance fault is found and the appliance is within the guarantee period. Reasonable evidence of this must be supplied on request. i.e. a completed Commissioning and service record and has been regularly serviced.
- A call-out charge will be made where:
 - The appliance is outside the guarantee period or has not been serviced in accordance with the manufacturers instructions.
 - Our Field Service Engineer finds no fault with the appliance.
 - The cause of breakdown is misuse or with other parts of your plumbing/heating system, or with equipment not supplied by Worcester, Bosch Group.



No appliance fault is found on over 30% of all service calls.

- ▶ In the case of a suspected fault, refer to the basic checks earlier in this section.

In the event of an appliance fault or breakdown please contact Worcester, Bosch Group appointments team on 0330 123 9339. Your advisor will arrange for an engineer to call with the minimum of delay; under normal circumstances this will be from 1 - 3 working days (excluding weekends and bank holidays) for priority breakdown situations (no hot water and/or heating).

8.1 Troubleshooting

If there is fault in the system, there will be a message shown on the display. The cause of the fault is coded (e.g. fault code 232).

- ▶ Press the ▲ and ▼ keys together until fault disappears. The appliance starts up again and the current supply temperature is displayed.

If a fault persists:

- ▶ Contact the contractor or the customer service.
- ▶ Provide them with the displayed fault code and the device data (→ table 2).

8.2 Extreme cold weather

In certain instances where the condensate pipe work is run externally or in an unheated area, such as a garage, the condensate pipe work can be at risk of freezing, even if well insulated.

A frozen/blocked condensate pipe will cause the boiler to shut down. Worcester, Bosch Group have available helpful videos on thawing frozen condensate pipe work on our website in the Customer service section.



WARNING:

Falling hazard!

Failure to follow this guidance may result in personal injury.

- ▶ Only attempt to thaw a condensate pipe that is at ground level and easily accessible.
- ▶ Never attempt to thaw a condensate pipe that is at height.



CAUTION:

Risk of damage to pipe work!

Thermal shock from boiling water can damage plastic pipes.

- ▶ **DO NOT** use boiling water to thaw the condensate pipe!

If the condensate pipe has frozen:

- ▶ Locate the blockage.
 - It is likely that the pipe is frozen at the most exposed point outside the building or where there is an obstruction to flow. This could be the open end of the pipe, at a bend or elbow, or where there is a sag in the pipe in which condensate can collect.
 - The location of the blockage should be identified as closely as possible before taking further action.
- ▶ Thaw the frozen pipe.
 - The pipe can be thawed by applying a hot water bottle, a microwaveable heating pack (the sort used for muscular aches and pains) or a cloth soaked in hot water to the exterior of the pipe, close to the point of blockage.
 - Hot water, but not boiling, can also be poured onto the pipe from a watering can or similar container.
 - Care must be taken at pedestrian areas where this water may freeze and create a slip hazard.

- ▶ Worcester, Bosch Group have available on our website helpful videos in the Customer service section to aid in thawing a frozen pipe.
- ▶ Reset the appliance and wait two or three minutes for the appliance to restart.
- ▶ Contact Worcester, Bosch Group Appointments Team on: 0330 123 9339, if the boiler does not restart.
- ▶ Contact your installer in order to find a permanent solution to the problem.

9 Environmental protection and disposal

Environmental protection is a fundamental corporate strategy of the Bosch Group.

The quality of our products, their economy and environmental safety are all of equal importance to us and all environmental protection legislation and regulations are strictly observed.

We use the best possible technology and materials for protecting the environment taking account of economic considerations.

Packaging

Where packaging is concerned, we participate in country-specific recycling processes that ensure optimum recycling.

All of our packaging materials are environmentally compatible and can be recycled.

Used appliances

Used appliances contain valuable materials that can be recycled.

The various assemblies can be easily dismantled. Synthetic materials are marked accordingly. Assemblies can therefore be sorted by composition and passed on for recycling or disposal.

Old electrical and electronic appliances



Electrical or electronic appliances that are no longer serviceable must be collected separately and sent for environmentally compatible recycling (in accordance with the European Directive on Waste Electrical and Electronic Equipment).

To dispose of old electrical or electronic appliances, you should use the return and collection systems put in place in the country concerned.

Batteries

Batteries must not be disposed together with your household waste. Used batteries must be disposed of in local collection systems.

10 Tips on energy saving

Heating economically

The appliance provides a high level of comfort whilst keeping fuel consumption and the environment effects as low as possible.

The appliance is controlled in such a way that it delivers heat at the correct rate and only if there is a clear demand from the system.

Central heating systems with thermostatic radiator valves

With modern heating systems set around a 20 °C heat loss, the optimum setting for a condensing boiler will be approximately 73 °C for the central heating temperature. This is to ensure a return temperature of less than 52 °C.

The system must be balanced correctly and the radiators may need upgrading. This allows the boiler to condense as much as possible for the central heating system.

The temperature of each room can be set individually (except primary room with the room thermostat) using the thermostatic radiator valves.

Room thermostats

Reducing the setting of the room thermostat by 1 °C can reduce fuel consumption by up to 10%.

New control systems

Upgrade your heating control system if necessary with the latest equipment available.

Roof insulation

Around 30% of the heat loss from a property is through the roof. Replace any old insulation with new insulation, preferably of around 200mm thickness or more.

Window frames

Single glazed windows, particularly those with steel frames, can lose a great deal of heat. Consideration should be given to replacement with PVCu or wooden framed double glazed units.

Radiators

If a radiator is sited underneath a window, its performance will be affected if the curtains are allowed to drape over the radiator. Shelves fitted above or in front of the radiator should also be avoided.

It is advisable to manually adjust all thermostatic radiator valves every 2 - 3 months to prevent them sticking. Ensure radiator valves are correctly set and not damaged.

Draughts

Try to ensure that draughts around doors, windows, letter boxes and keyholes etc. are reduced by using a suitable draught excluder.



WARNING:

Air vents!

- ▶ Do not block or seal any air vents that are installed to ensure that the appliance operates safely.

Curtains

Lined curtains, or heavier full length curtains can provide excellent insulation. However, always ensure that the curtains do not drape over radiators.

11 Your guarantee

This appliance has a guarantee against faulty materials or workmanship from the date of installation subject to the following terms and conditions:

- During the period of this guarantee any components of the appliance that are proven to be faulty or defective in manufacture will be exchanged or repaired free of charge by Bosch Thermotechnology Ltd.
- The householder may be asked to prove the date of installation, that the appliance was correctly commissioned and, where appropriate, serviced to the satisfaction of Bosch Thermotechnology Ltd. These should be documented in the commissioning and service records in the Installation and Maintenance Instructions.
- The appliance has been used only for the normal domestic purposes for which it was designed.

This guarantee does not affect your statutory rights.

Guarantee registration

Your appliance/product carries a guarantee against faulty material or manufacture subject to Terms and Conditions.

To read the full Terms & Conditions please visit us on-line at www.worcester-bosch.co.uk/guarantee.

Your statutory rights are not affected by the manufacturer's guarantee

12 Energy consumption

12.1 Product data on energy consumption

The following product data comply with the requirements of the EU Regulations No. 811/2013, No. 812/2013, No. 813/2013 and No. 814/2013 supplementing the Regulation (EU) 2017/1369.

Product data	Symbol	Unit	7 738 100 800/849	7 738 100 801/850
Product type	–	–	GR8300iW 30 C NG/LPG	GR8300iW 35 C NG/LPG
Condensing boiler	–	–	Yes	Yes
Low temperature boiler	–	–	No	No
B1 boiler	–	–	No	No
Cogeneration space heater	–	–	No	No
Equipped with a supplementary heater?	–	–	–	–
Combination heater	–	–	Yes	Yes
Rated heat output	P_{rated}	kW	30	34
Seasonal space heating energy efficiency	η_s	%	94	94
Energy Efficiency Class	–	–	A	A
Useful heat output				
At rated heat output and high temperature regime ¹⁾	P_4	kW	29.5	33.7
At 30 % of rated heat output and low temperature regime ²⁾	P_1	kW	9.9	11.3
Useful efficiency				
At rated heat output and high temperature regime ¹⁾	η_4	%	88.5	88.8
At 30 % of rated heat output and low temperature regime ²⁾	η_1	%	98.7	98.8
Auxiliary electricity consumption				
At full load	e_{max}	kW	0.067	0.048
At part load	e_{min}	kW	0.014	0.013
In standby mode	P_{SB}	kW	0.001	0.001
Other items				
Standby heat loss	P_{stby}	kW	0.071	0.071
Ignition burner power consumption	P_{ign}	kW	0.000	0.000
Emissions of nitrogen oxides (only gas- or oil fired)	NO_x	mg/kWh	23	25
Annual energy consumption	Q_{HE}	kWh	–	–
Annual energy consumption	Q_{HE}	GJ	50	60
Sound power level, indoors	L_{WA}	dB	53	53
Additional data for combination heaters				
Declared load profile	–	–	XL	XL
Water heating energy efficiency	η_{wh}	%	89	87
Water heating energy efficiency class	–	–	A	A
Daily electricity consumption (average climate conditions)	Q_{elec}	kWh	0.180	0.168
Annual electricity consumption	AEC	kWh	40	37
Daily fuel consumption	Q_{fuel}	kWh	21.652	22.174
Annual fuel consumption	AFC	GJ	17	18
Indication about ability working only during off-peak hours	–	–	No	No
Other load profiles	–	–	–	–
Standing loss	S	W	–	–
Storage volume	V	l	–	–
Non-solar storage volume (Vbu)	Vbu	l	–	–

1) High-temperature regime means 60 °C return temperature at heater inlet and 80 °C feed temperature at heater outlet.

2) Low temperature means for condensing boilers 30 °C, for low-temperature boilers 37 °C and for other heaters 50 °C return temperature (at heater inlet).

Table 8 Product data on energy consumption Greenstar 8000 Life

Product data	Symbol	Unit	7 738 100 802/851	7 738 100 803/852
Product type	–	–	GR8300iW 40 C NG/LPG	GR8300iW 45 C NG/LPG
Condensing boiler	–	–	Yes	Yes
Low temperature boiler	–	–	No	No
B1 boiler	–	–	No	No
Cogeneration space heater	–	–	No	No
Equipped with a supplementary heater?	–	–	–	–
Combination heater	–	–	Yes	Yes
Rated heat output	P_{rated}	kW	34	34
Seasonal space heating energy efficiency	η_s	%	94	94
Energy Efficiency Class	–	–	A	A
Useful heat output				
At rated heat output and high temperature regime ¹⁾	P_4	kW	33.7	33.7
At 30 % of rated heat output and low temperature regime ²⁾	P_1	kW	11.3	11.3
Useful efficiency				
At rated heat output and high temperature regime ¹⁾	η_4	%	88.8	88.8
At 30 % of rated heat output and low temperature regime ²⁾	η_1	%	98.8	98.8
Auxiliary electricity consumption				
At full load	e_{max}	kW	0.048	0.048
At part load	e_{min}	kW	0.013	0.013
In standby mode	P_{SB}	kW	0.001	0.001
Other items				
Standby heat loss	P_{stby}	kW	0.071	0.071
Ignition burner power consumption	P_{ign}	kW	0.000	0.000
Emissions of nitrogen oxides (only gas- or oil fired)	NO_x	mg/kWh	25	24
Annual energy consumption	Q_{HE}	kWh	–	–
Annual energy consumption	Q_{HE}	GJ	60	62
Sound power level, indoors	L_{WA}	dB	53	53
Additional data for combi boilers				
Declared load profile	–	–	XL	XL
Water heating energy efficiency	η_{wh}	%	86	86
Water heating energy efficiency class	–	–	A	A
Daily electricity consumption (average climate conditions)	Q_{elec}	kWh	0.177	0.170
Annual electricity consumption	AEC	kWh	39	37
Daily fuel consumption	Q_{fuel}	kWh	22.656	22.512
Annual fuel consumption	AFC	GJ	18	18
Indication about ability working only during off-peak hours	–	–	No	No
Other load profiles	–	–	–	–
Standing loss	S	W	–	–
Storage volume	V	l	–	–
Non-solar storage volume (Vbu)	Vbu	l	–	–

1) High-temperature regime means 60 °C return temperature at heater inlet and 80 °C feed temperature at heater outlet.

2) Low temperature means for condensing boilers 30 °C, for low-temperature boilers 37 °C and for other heaters 50 °C return temperature (at heater inlet).

Table 9 Product data on energy consumption Greenstar 8000 Life

Product data	Symbol	Unit	7 738 100 804/853
Product type	–	–	GR8300iW 50C NG/LPG
Condensing boiler	–	–	Yes
Low temperature boiler	–	–	No
B1 boiler	–	–	No
Cogeneration space heater	–	–	No
Equipped with a supplementary heater?	–	–	–
Combination heater	–	–	Yes
Rated heat output	P_{rated}	kW	34
Seasonal space heating energy efficiency	η_s	%	94
Energy Efficiency Class	–	–	A
Useful heat output			
At rated heat output and high temperature regime ¹⁾	P_4	kW	33.7
At 30 % of rated heat output and low temperature regime ²⁾	P_1	kW	11.3
Useful efficiency			
At rated heat output and high temperature regime ¹⁾	η_4	%	88.8
At 30 % of rated heat output and low temperature regime ²⁾	η_1	%	98.8
Auxiliary electricity consumption			
At full load	e_{max}	kW	0.048
At part load	e_{min}	kW	0.013
In standby mode	P_{SB}	kW	0.001
Other items			
Standby heat loss	P_{stby}	kW	0.071
Ignition burner power consumption	P_{ign}	kW	0.000
Emissions of nitrogen oxides (only gas- or oil fired)	NO_x	mg/kWh	24
Annual energy consumption	Q_{HE}	kWh	–
Annual energy consumption	Q_{HE}	GJ	62
Sound power level, indoors	L_{WA}	dB	53
Additional data for combi boilers			
Declared load profile	–	–	XL
Water heating energy efficiency	η_{wh}	%	87
Water heating energy efficiency class	–	–	A
Daily electricity consumption (average climate conditions)	Q_{elec}	kWh	0.172
Annual electricity consumption	AEC	kWh	38
Daily fuel consumption	Q_{fuel}	kWh	22.368
Annual fuel consumption	AFC	GJ	18
Indication about ability working only during off-peak hours	–	–	No
Other load profiles	–	–	–
Standing loss	S	W	–
Storage volume	V	l	–
Non-solar storage volume (Vbu)	Vbu	l	–

1) High-temperature regime means 60 °C return temperature at heater inlet and 80 °C feed temperature at heater outlet.

2) Low temperature means for condensing boilers 30 °C, for low-temperature boilers 37 °C and for other heaters 50 °C return temperature (at heater inlet).

Table 10 Product data on energy consumption Greenstar 8000 Life



TECHNICAL SUPPORT: 0330 123 3366
RENEWABLE SUPPORT: 0330 123 9229
CONTROLS AND CONNECTIVITY TEAM: 0330 123 3641
APPOINTMENTS: 0330 123 9339
SPARES: 0330 123 9779
LITERATURE: 0330 123 9119
TRAINING: 0330 123 0166
SALES: 0330 123 9669

Bosch Thermotechnology Ltd.
Cotswold Way, Warndon
Worcester WR4 9SW
United Kingdom
Tel. 0330 123 9559
worcester-bosch.co.uk

